

PRODUCT DATASHEET

Confidex Viking™ Wirepas



Confidex Viking™ Wirepas tags utilize the unique Wirepas Massive (WM) protocol and software stack which provides many benefits for enabling implementation of asset tracking and IoT applications in large scale. WM is easily scalable and can have large coverage as all Confidex Viking™ Wirepas tags are able to route data between the devices and back-end system.

ELECTRICAL SPECIFICATION

Device type

Bluetooth® Low Energy beacon, Battery powered

Wireless interface protocol

Wirepas Massive protocol v5.2

NFC: ISO/IEC 14443A

Compliance (Declaration of Conformity)

Europe (CE), UK (UKCA), USA (FCC), Canada (IC), Australia/New Zealand (ACMA), South-Korea (KC), Japan (MIC), Ukraine (UkrSEPRO), Brazil (ANATEL)

Operational frequency

ISM: 2402 - 2480 MHz

NFC: 13,56 MHz

SOC

Nordic Semiconductor NRF52832

Memory configuration

512 kB FLASH, 64 kB RAM

Configuration interface

NFC interface for manual configuration

Self-provisioning remotely via Wirepas network

Sensors*

Built-in temperature sensor and hall switch

Optional accelerometer

Sensitivity / Max transmit power

-96 dBm / +4 dBm

Read range**

Up to 100 m / 330 ft.

Battery type (total capacity)

2 x CR2477 (2000 mAh) coin batteries

Applicable surface materials

Can be attached to any surface

* Temperature sensor is located inside the housing, which limits real time measurement of the ambient temperature.

** Read ranges can vary significantly depending on the mounting surface and environment.

MECHANICAL SPECIFICATION

Housing material

High quality PC/ASA, white RAL9003 (15% recycled)

Enclosure IP class

IP69K

Weight

45 g

Tag dimensions

56 x 55 x 19 mm / 2.20 x 2.13 x 0.75 in (M5 size hole)

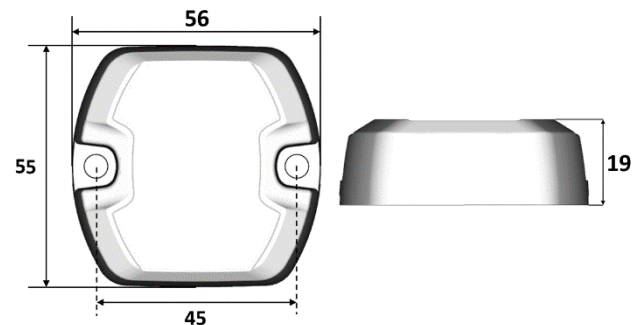

ENVIRONMENTAL RESISTANCE

Operating temperature

-20°C to +60°C / -4°F to +140°F

EN 60068-2-14: 2009, Test N: Change of temperature

Vibration resistance

EN 60068-2-6: 2008, Test Fc: Vibration, 10G

EN 60068-2-27: 2009, Test Ea: Shock, 20G

ESD immunity

±8 kV according to EN 61000-4-2 (air discharge)

±4 kV according to EN 61000-4-2 (contact discharge)

Chemical resistance***

No physical or performance changes in:

- 168h Motor oil exposure
- 48h Salt water (salinity 10%) exposure
- 48h Sulfuric acid (10%, pH 2) exposure
- 48h NaOH (10%, pH 13) exposure

Generally good resistance with moderate concentrations of acids, alcohols, alkalis, detergents, and cleaners.

Acetone should be avoided

***Values are the best recommendations; resistance against environmental conditions depends on the combination of all influencing factors, exposure duration and chemical concentrations. Thus, product's final suitability for certain environmental conditions is recommended to be tested. Contact Confidex for more specific information.

SYSTEM DESCRIPTION

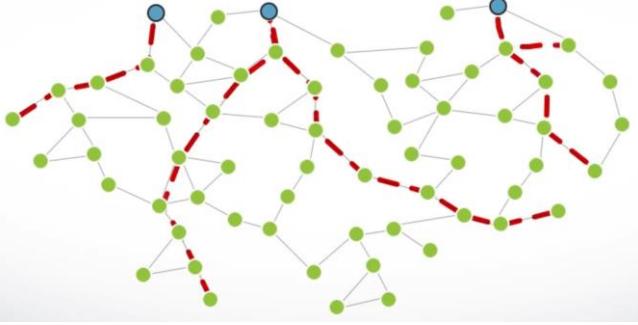

With Wirepas Massive, all devices can function as routers for other devices. Confidex Viking™ Wirepas tags can be configured to work in two modes – nodes or routers. Below described the main configuration parameters for Confidex Viking™ Wirepas devices.

Confidex Viking™ Wirepas comes with standard Wirepas parameters by default. Wirepas tags can be configured to self-provision and join to an existing Wirepas network. Tags can also be factory configured with customer specific parameters and personalized with a custom label to ease the deployment and tag identification in the field.

INSTALLATION INSTRUCTIONS

1. Mechanical fixing – Screw

Mechanical fixing is recommended to be used in every application that includes risk for high mechanical stress or low temperature during tag fixing. Screw size M5 is to be used for fixing.

2. Mechanical fixing – Cable tie

Plastic or metallic cable ties can also be used for fixing Confidex Viking™. Maximum width of cable tie is 4 mm.



3. High performance acrylic adhesive

When mounting the tag with adhesive, clean and dry the surface for obtaining the maximum bond strength.

ORDER INFORMATION

3003404 Confidex Viking™ Wirepas, no accelerometer

- White, default configuration and no label

3003244 Confidex Viking™ Wirepas, with accelerometer

- White, default configuration and no label

3003637 Confidex Viking™ Wirepas Sample Kit

- Contains 5 pcs of item 3003244

Availability: Please contact Confidex Smart Industries Sales at www.confidex.com/contact-us

For additional information and technical support, please contact us in contact.BLE@confidex.com

DISCLAIMER

THE MATERIALS, PRODUCTS AND SERVICES ARE SOLD SUBJECT TO ITS STANDARD CONDITIONS OF SALE, WHICH ARE INCLUDED IN THE APPLICABLE DISTRIBUTOR OR OTHER SALES AGREEMENT. ALTHOUGH ANY INFORMATION, RECOMMENDATIONS, OR ADVICE CONTAINED HEREIN IS GIVEN IN GOOD FAITH, CONFIDEX MAKES NO WARRANTY OR GUARANTEE, EXPRESS OR IMPLIED, (i) THAT THE RESULTS DESCRIBED HEREIN WILL BE OBTAINED UNDER END-USE CONDITIONS, OR (ii) AS TO THE EFFECTIVENESS OR SAFETY OF ANY DESIGN INCORPORATING ITS PRODUCTS, MATERIALS, SERVICES, RECOMMENDATIONS OR ADVICE. EXCEPT AS PROVIDED IN CONFIDEX STANDARD CONDITIONS OF SALE, CONFIDEX AND ITS REPRESENTATIVES SHALL IN NO EVENT BE RESPONSIBLE FOR ANY LOSS RESULTING FROM ANY USE OF ITS MATERIALS, PRODUCTS OR SERVICES DESCRIBED HEREIN.

Each user bears full responsibility for making its own determination as to the suitability of Confidex products, materials, services, recommendations, or advice for its own particular use. Each user must identify and perform all tests and analyses necessary to assure that its finished systems incorporating Confidex products, materials, or services will be safe and suitable for use under end-use conditions. Nothing in this or any other document, nor any oral recommendation or advice, shall be deemed to alter, vary, supersede, or waive any provision of this Disclaimer, unless any such modification is specifically agreed to in a writing signed by Confidex.

This device complies with Part 15 of the FCC Rules. Operation is subject to the following two conditions: (1) this device may not cause harmful interference, and (2) this device must accept any interference received, including interference that may cause undesired operation.

