



SIMPLE TO INTEGRATE

Designed for easy integration, the Gryphon I GFS4100 reader provides a simple 'plug-and-play' solution for system designers. Constructed using high-impact resin to withstand repeated cleanings with solvents and disinfectant solutions, the sealed enclosure meets industrial standards against water and particulates to provide dependable and reliable scanning performance.

ADVANCED IMAGING TECHNOLOGY

The Gryphon I GFS4100 OEM module shares the same excellent reading characteristics found in the premium line of Gryphon™ 4100 series of handheld devices. Featuring outstanding near-field reading, a wide angle field-of-view, improved motion tolerance and snappy reading, it also offers integrators excellent performance on decoding poor or damaged codes. As with all Gryphon readers, the GFS4100 reader offers users additional good-read visual confirmation with Datalogic's patented 'Green Spot' technology.

CONTINUOUS SCANNING CAPABILITY

The Gryphon I GFS4100 reader supports several modes that can be used as a trigger. The module has the ability to automatically sense objects and trigger itself. A continuous scan mode transmits data whenever a bar code passes into its field of view. The reader can be triggered remotely using input from programmable logic controller (PLC) or sensor.



FEATURES

- High-speed imaging for fast moving codes
- Read rate: 320 reads/second
- Excellent near-field reading at the scan window
- Supports all common linear (1D) bar codes including GS1 DataBar™
- Reads high resolution bar codes up to 3 mils
- Datalogic's patented Green Spot for good-read feedback
- Integrated good-read beeper
- Automatic sensing or manual trigger options available
- Integrated interface cable
- High-impact resin creates a solvent-tolerant enclosure
- Water and Particulate Sealing Rating: IP54
- EASEOFCARE Service Plans offer a wide range of service options to protect your investment, ensuring maximum productivity and ROI

INDUSTRY-APPLICATIONS

- OEM Applications:
 - Service Kiosks
 - Price Verifiers
 - Ticket Readers
 - Document Handling
 - Medical Laboratories
 - Vending Machines
 - Additional Automated Equipment

DECODING CAPABILITY

1D / LINEAR CODES Autodiscriminates all standard 1D codes including GS1 DataBar™ linear codes.

ELECTRICAL

CURRENT Operating (Typical): 390 mA
Standby/Idle (Typical): GFS4170: < 2.5 mA

INPUT VOLTAGE 5 VDC +/- 5%

ENVIRONMENTAL

AMBIENT LIGHT 0 - 100,000 lux

DROP RESISTANCE Withstands repeated drops from 0.76 m / 2.50 ft onto a concrete surface

ESD PROTECTION (AIR DISCHARGE) 16 kV

HUMIDITY (NON-CONDENSING) 95%

PARTICULATE AND WATER SEALING IP54

TEMPERATURE Operating: 0 to 50 °C / 32 to 122 °F
Storage/Transport: -25 to 50 °C / -13 to 122 °F

INTERFACES

INTERFACES RS-232; USB

PHYSICAL CHARACTERISTICS

COLORS AVAILABLE Grey; Other colors and custom logo options are available for minimum quantity purchase.

DIMENSIONS 3.9 x 5.7 x 5.8 cm / 1.5 x 2.2 x 2.3 in

WEIGHT 170.0 g / 6.0 oz (including a 2.0 m / 6.6 ft RS-232 cable)

READING PERFORMANCE

IMAGER SENSOR CCD Solid State

LIGHT SOURCE Illumination: Dual LED Array 630 - 670 nm

PRINT CONTRAST RATIO (MINIMUM) 15%

READ RATE (MAXIMUM) 320 reads/sec.

READING ANGLE Pitch: +/- 65°; Roll (Tilt): +/- 35°; Skew (Yaw): +/- 65°

READING INDICATORS Beeper; Datalogic 'Green Spot' Good Read Feedback; Good Read LED

RESOLUTION (MAXIMUM) 0.076 mm / 3 mils

READING RANGES

TYPICAL DEPTH OF FIELD Minimum distance determined by symbol length and scan angle.
Printing resolution, contrast, and ambient light dependent.
5 mils: 5.0 to 16.0 cm / 2.0 to 6.3 in
8 mils: 3.0 to 27.0 cm / 1.2 to 10.6 in
10 mils: 1.5 to 30.0 cm / 0.6 to 11.8 in
13 mils: 3.0 to 40.0 cm / 1.2 to 15.7 in
20 mils: up to 60.0 cm / up to 23.6 in

SAFETY & REGULATORY

AGENCY APPROVALS The product meets necessary safety and regulatory approvals for its intended use.
The Quick Reference Guide for this product can be referred to for a complete list of certifications.

ENVIRONMENTAL COMPLIANCE Complies to China RoHS; Complies to EU RoHS

LED CLASSIFICATION IEC 60825-1 Class 1 LED Product

UTILITIES

DATALOGIC ALADDIN™ Datalogic Aladdin configuration program is available for download at no charge.

OPOS / JAVAPOS JavaPOS Utilities are available for download at no charge.
OPOS Utilities are available for download at no charge.

REMOTE HOST DOWNLOAD Lowers service costs and improves operations.

WARRANTY

WARRANTY 3-Year Factory Warranty

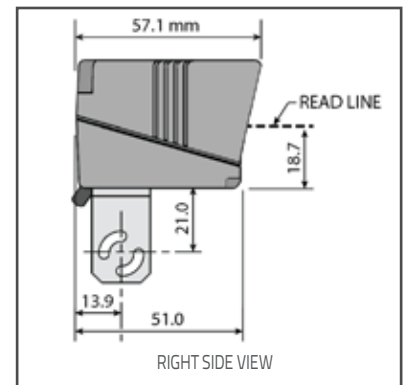
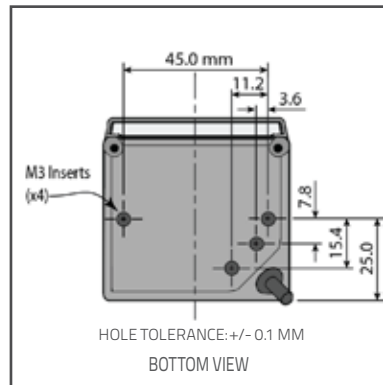
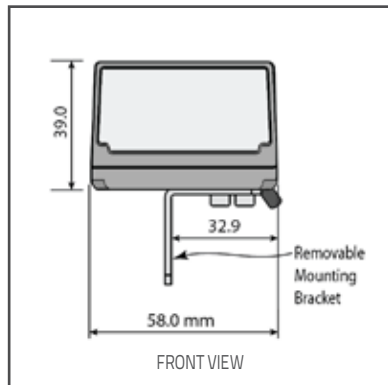



800 729 0236
www.logiscenter.us



0241 9550 9225
www.logiscenter.de



01 82 88 44 70
www.logiscenter.fr



020 3318 8265
www.logiscenter.co.uk



0720 115814
www.logiscenter.at



02 58 80 583
www.logiscenter.be



911 433 048
www.logiscenter.com



02 4792 1697
www.logiscenter.it



308 800 842
www.logiscenter.pt

About LOGISCENTER

Logiscenter is the leading provider of automatic identification and data capture equipments. Our products include barcode printing and reading devices, mobile computing devices, wireless access points, identification cards, and consumables.

Reasons to work with us

Our customers come first. Our objective is not only selling our products but also holding a long-lasting relationship with our customers, based on the benefits and advantages we create for you and your company.

The best brands. We offer products from the best manufacturers worldwide.

Expert technical support team. Our support staff are experts in the products we sell. But not just the products, they can tell you the best solution for your particular problem or need.

Largest stock. We have a permanent stock of more than 60,000 products.

Same-day shipping. For all orders placed and confirmed before 16:00 on working days.

Best prices. With Logiscenter, you can be sure that you are paying a fair price for your products, we will not overcharge you.

Easy returns. Damaged or defective products can be returned easily, for an exchange or reimbursement.



All Brands Technical Service

Our Brands



Solutions for: Industry • Consumer • Mobility Transportation and Logistics • Retail • Health



Label printers

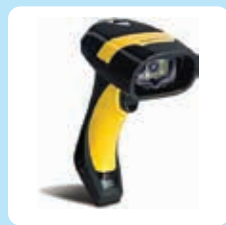

Barcode readers

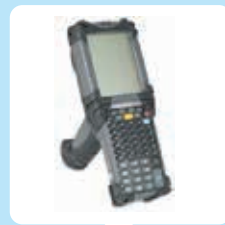

Data terminals & PDA



PVC card printers



RFID



Consumables
(labels, ribbons, PVC cards)